

016-750SP

Shower Panel
Panel de Ducha
Colonne de Douche

Quick Installation Guide Guía de Instalación Rápida Guide d'Installation Rapide

Installation Support • Soporte de instalación • Support d'installation

Personal Assistance, Product Specs, & "How-to" Questions:

Asistencia personal, especificaciones del producto y preguntas sobre "cómo hacerlo":

Aide personnelle, spécifications du produit et questions « pratico-pratiques » :

1-800-340-7608
pfisterfaucets.ca

⚠ WARNING / ADVERTENCIA / AVERTISSEMENT

To reduce the risk of injury or property damage, read all instructions before installing product. Wear safety goggles. Product must be installed in accordance with all state & local plumbing & building codes. Call a professional if you are uncertain about installing this product.

Para disminuir el riesgo de lesiones o daños a la propiedad, lea todas las instrucciones antes de instalar el producto. Utilice gafas de seguridad. El producto deberá instalarse de acuerdo con la normativa de plomería y construcción estatal y local. Llame a un profesional si no está seguro sobre cómo instalar este producto.

Pour réduire le risque de blessures ou de dommages, lire toutes les instructions avant d'installer le produit. Portez des lunettes de sécurité. Il faut installer le produit en respectant tous les codes de construction et de plomberie locaux et d'état. Appelez un professionnel si vous n'êtes pas certain de la façon d'installer ce produit.

Required Tools • Herramientas necesarias • Outils nécessaires

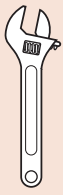

Adjustable Wrench
Llave ajustable
Clé à mollette

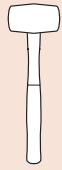

Mallet
Mazo
Maillet



Level
Burbuja de nivel
Niveau à Bulle



Pencil
Lápiz
Crayon



Phillips Screwdriver
Destornillador de estrella
Tournevis Phillips

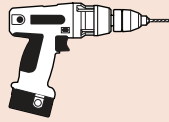

Power Drill
Taladro Eléctrico
Foreuse Électrique



Caulking or Sealant
Calafateo o sellante
Calfeutrage ou mastic



Safety Goggles
Anteojos de seguridad
Lunettes de sécurité



PTFE plumber's tape
Cinta para plomería PTFE
Ruban PTFE de plombier

Additional Helpful Tools Otras herramientas útiles Outils supplémentaires utiles

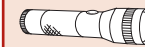

Flashlight
Linterna
Lampe-torche



Cloth
Paño de limpieza
Chiffon



A Helper
Un Ayudante
Une aide

Parts in the Box • Piezas en la caja • Pieces dans la boîte

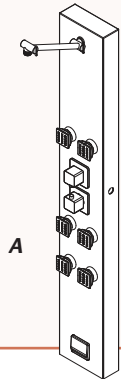

A



B (2X)



C (4X)



D (4X)

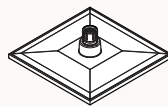

E



F



G



H



J

1 Turn Off Water Supply • Cierre el suministro de agua • Couper l'alimentation en eau

! Locate the water supply valves and shut off the water supply to shower panel installation area.

Ubique las entradas del suministro de agua y cierre las válvulas de suministro de agua.

Recherchez les entrées d'approvisionnement et fermer les robinets.

2

Preparation

Preparación

Préparation

Recommended Dimensional Layout

Disposición recomendada dimensional

Disposition recommandée dimensionnelle

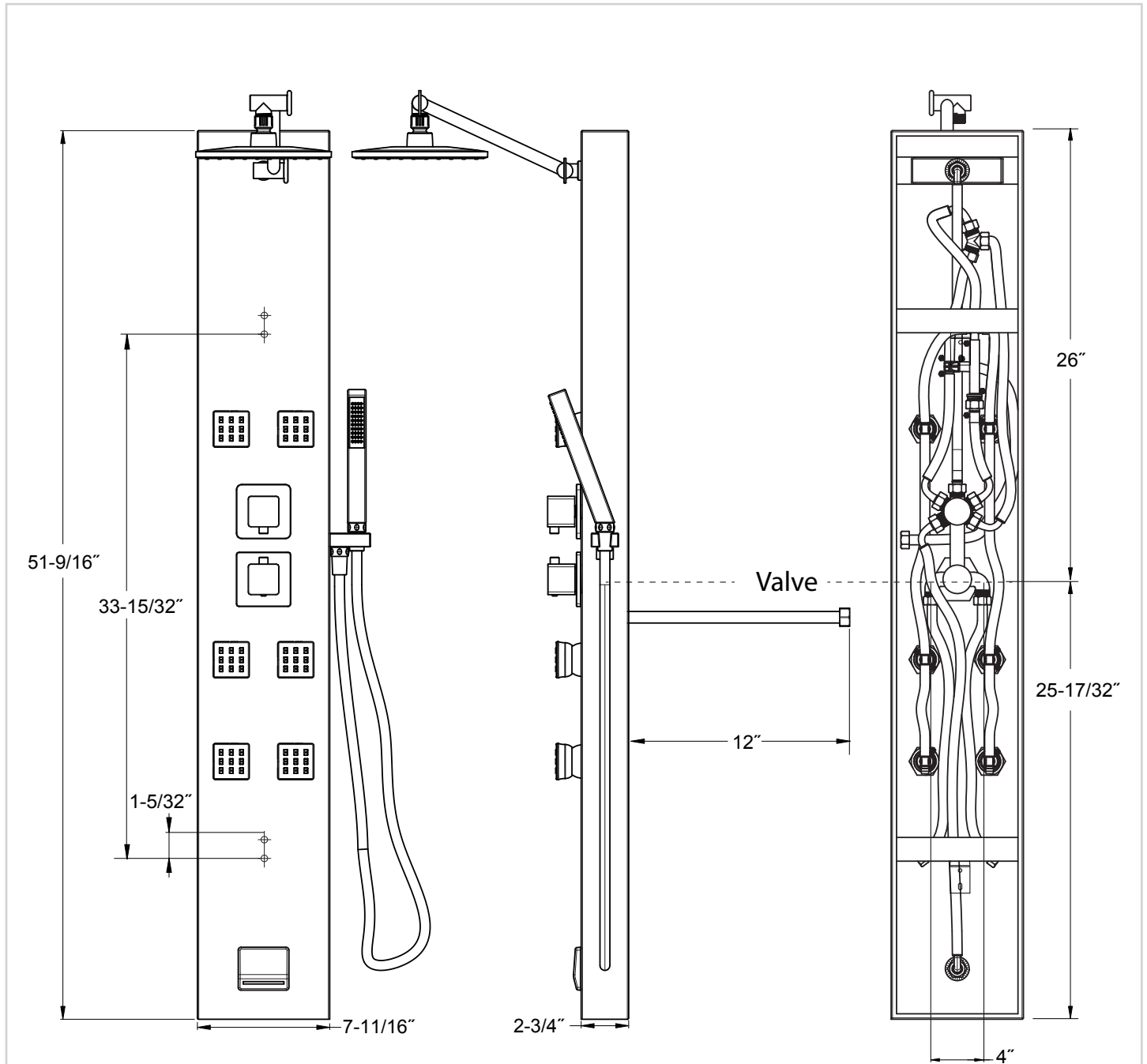

If you are remodeling ensure the shower panel covers the hole of existing valve assembly.

Si este panel de ducha es para remodelar asegúrese que cubra el agujero de la válvula existente.

Si ce panneau de douche est de remodeler sûr de couvrir le trou dans la vanne existante

3

Bracket Locations

Localizaciones del soporte

Endroits de parenthèse

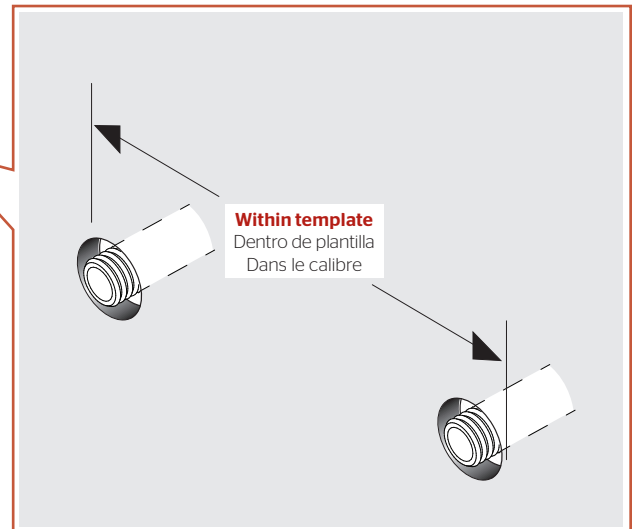
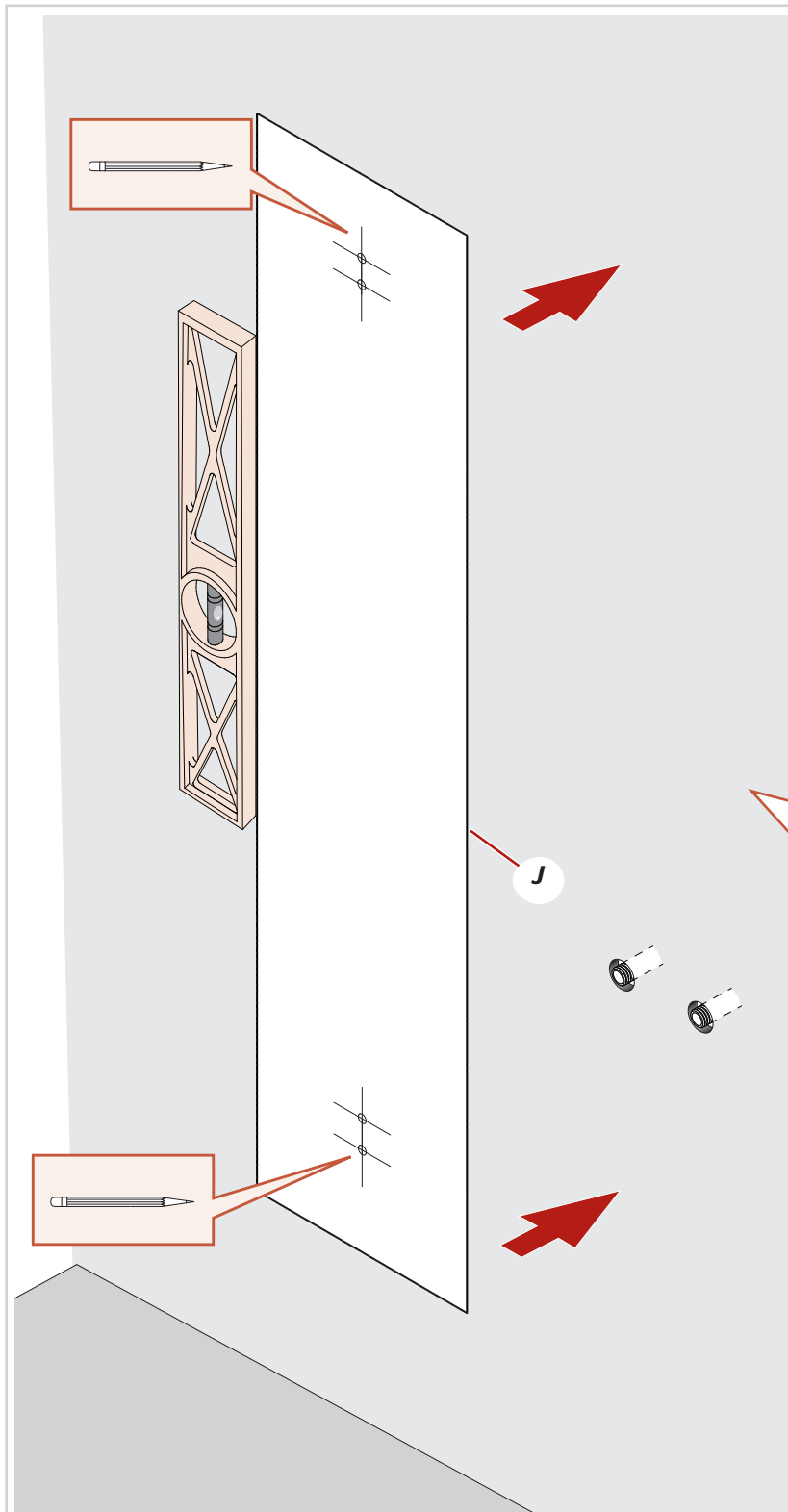
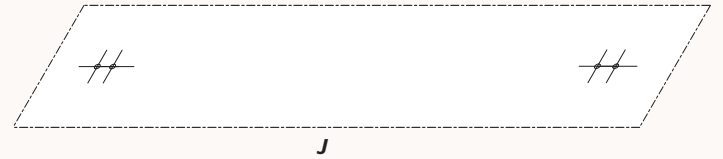
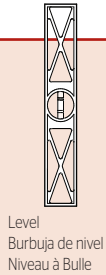





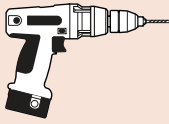

4

Bracket Installation

Intalación del soporte

Installation des supports de fixation

			
Safety Goggles Anteojos de seguridad Lunettes de sécurité	Power Drill Taladro Eléctrico Foreuse Électrique	Mallet Mazo Maillet	Phillips Screwdriver Destornillador de estrella Tournevis Philips

		
B (2X)	C (4X)	D (4X)

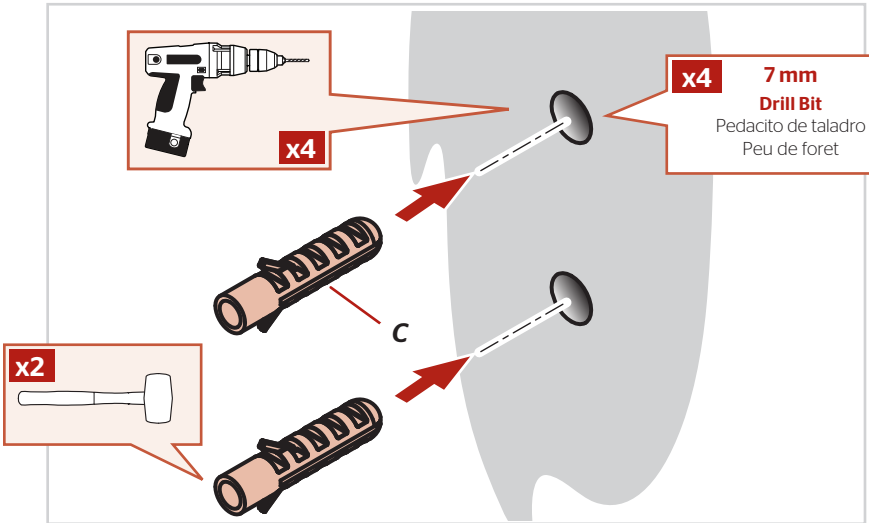

This diagram shows the first step of installation: drilling four holes into the bracket. A power drill is used with a 7 mm drill bit. A mallet is used to tap the bit into the material. The quantity of each tool is indicated as x4 for the drill and x2 for the mallet.

x4 **7 mm Drill Bit**
Pedacito de taladro
Peu de foret

x2

C

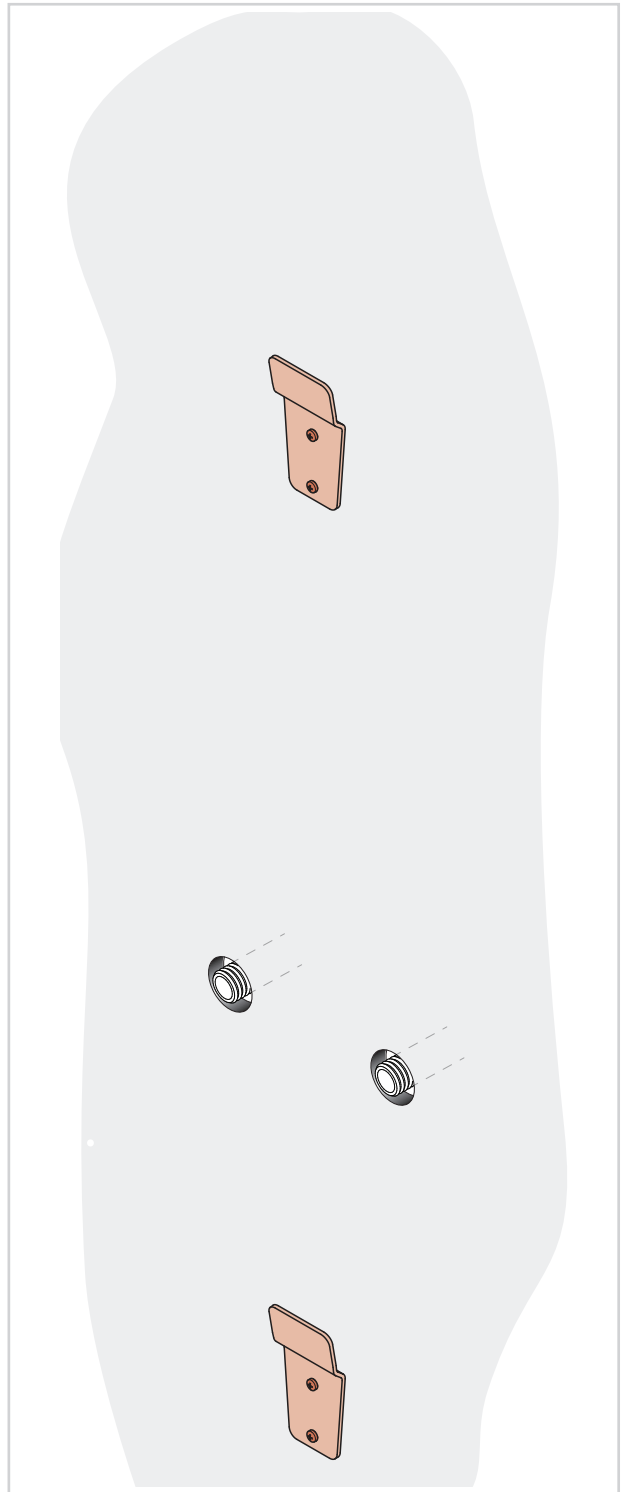

This diagram shows the bracket being placed on the surface. The four holes are aligned with the four pre-drilled holes in the surface. The quantity of brackets is indicated as x2.

x2

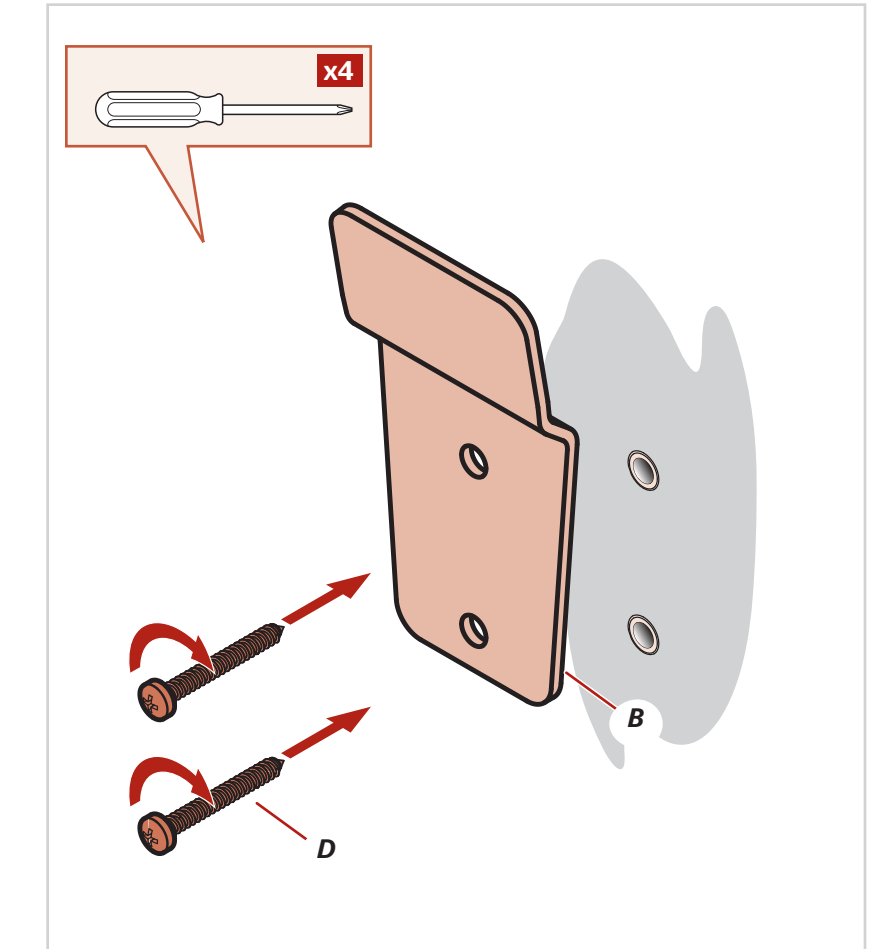

This diagram shows the second step of installation: screwing the bracket into the surface. A Phillips screwdriver is used to tighten the screws. The quantity of the screwdriver is indicated as x4.

x4

B

D

5

Connect Water Supply Lines and Mount

Conecte las tuberías de suministro de agua y montaje

Raccorder les conduites d'alimentation en eau et bâti



PTFE plumber's tape
Cinta para plomería PTFE
Ruban PTFE de plombier



Adjustable Wrench
Llave ajustable
Clé à mollette

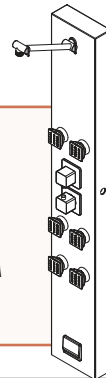

A

5A

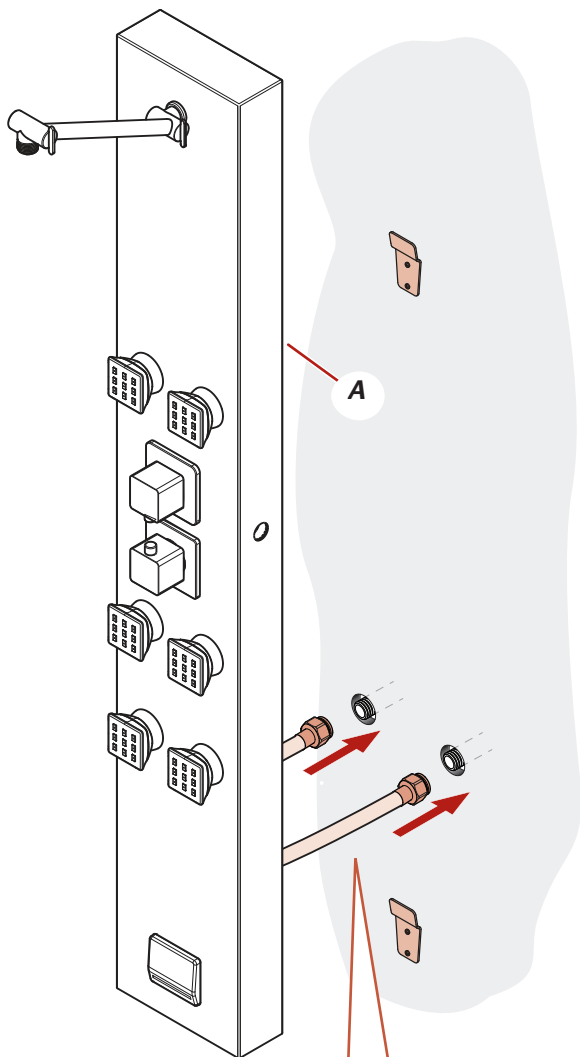

5B

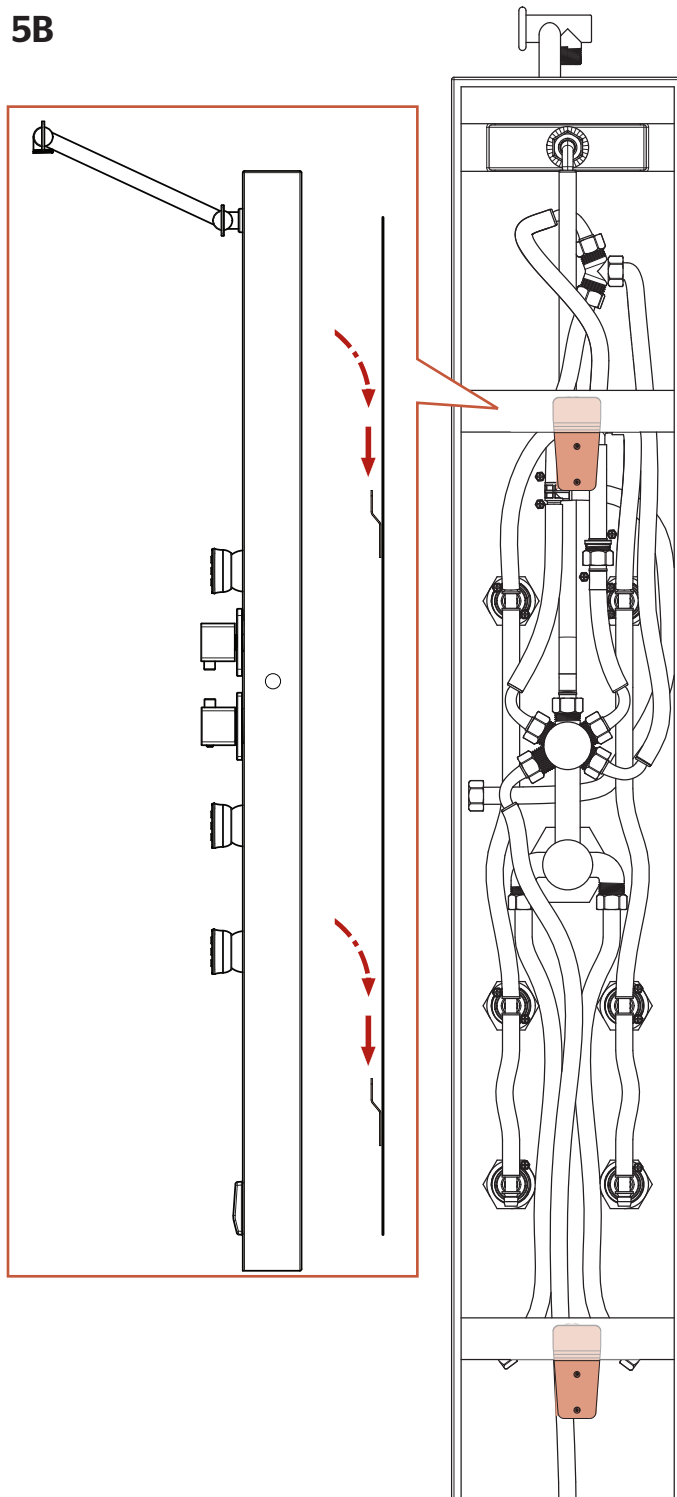

x2

Hot & Cold

Caliente y fría
Chaud et froid

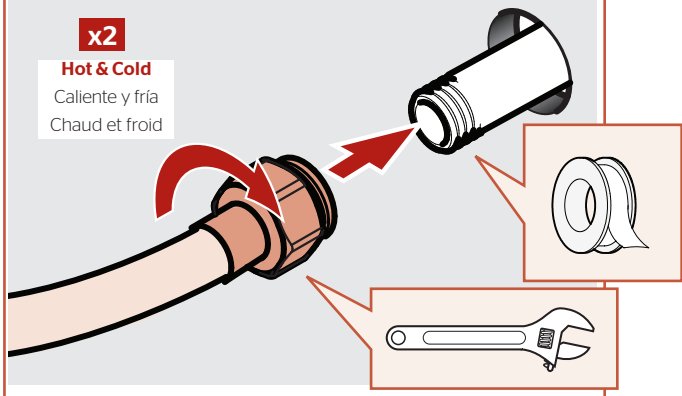

6

Hand Held Shower Holder and Showerhead

Estante de mano del sostenedor y la cabeza de ducha

Étagère tenue dans la main de support et la pomme de douche

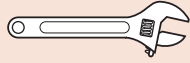

Adjustable Wrench
Llave ajustable
Clé à mollette



Caulking or Sealant
Calafateo o sellante
Calfeutrage ou mastic



H



F



G

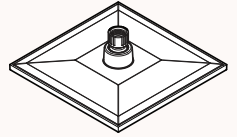

E

6A

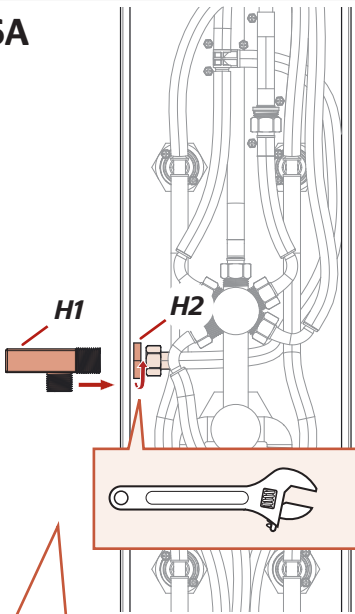

6B

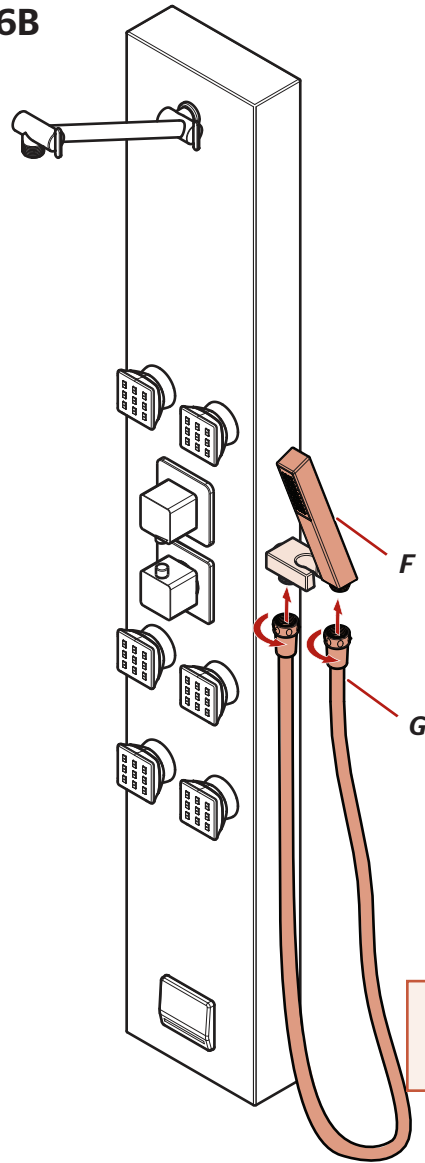

6C

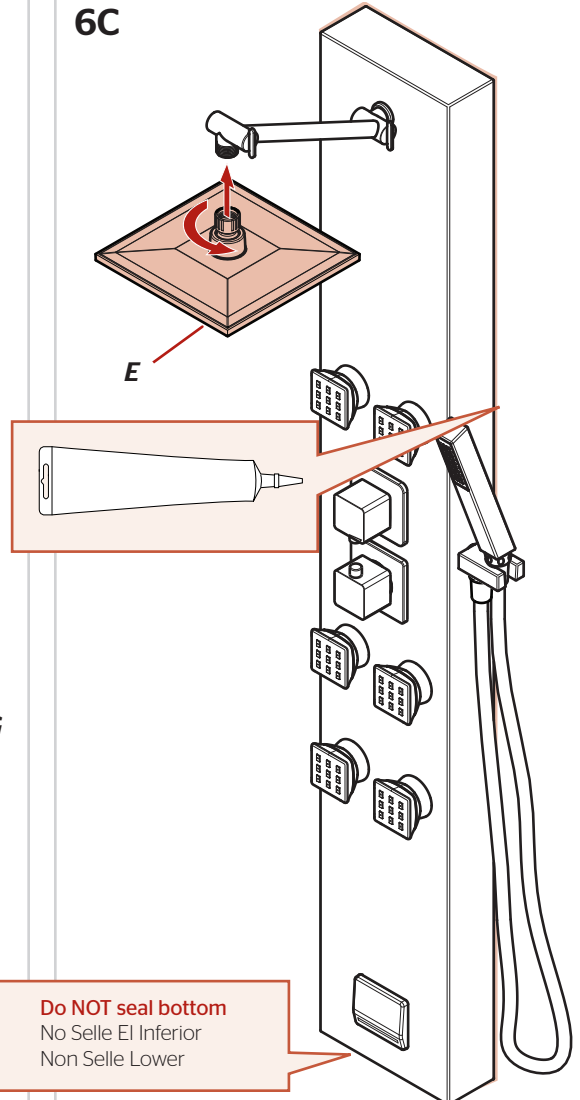

Do NOT seal bottom
No Selle El Inferior
Non Selle Lower

!
Check for leaks BEFORE using sealant
Compruebe si hay fugas ANTES de usar sellador
Vérifier les fuites AVANT d'utiliser étanchéité

Turn On Water & Confirm Proper Installation

Active el suministro de agua y confirme que la instalación está adecuadamente efectuada

Ouvrez l'eau et confirmez que l'installation est correcte

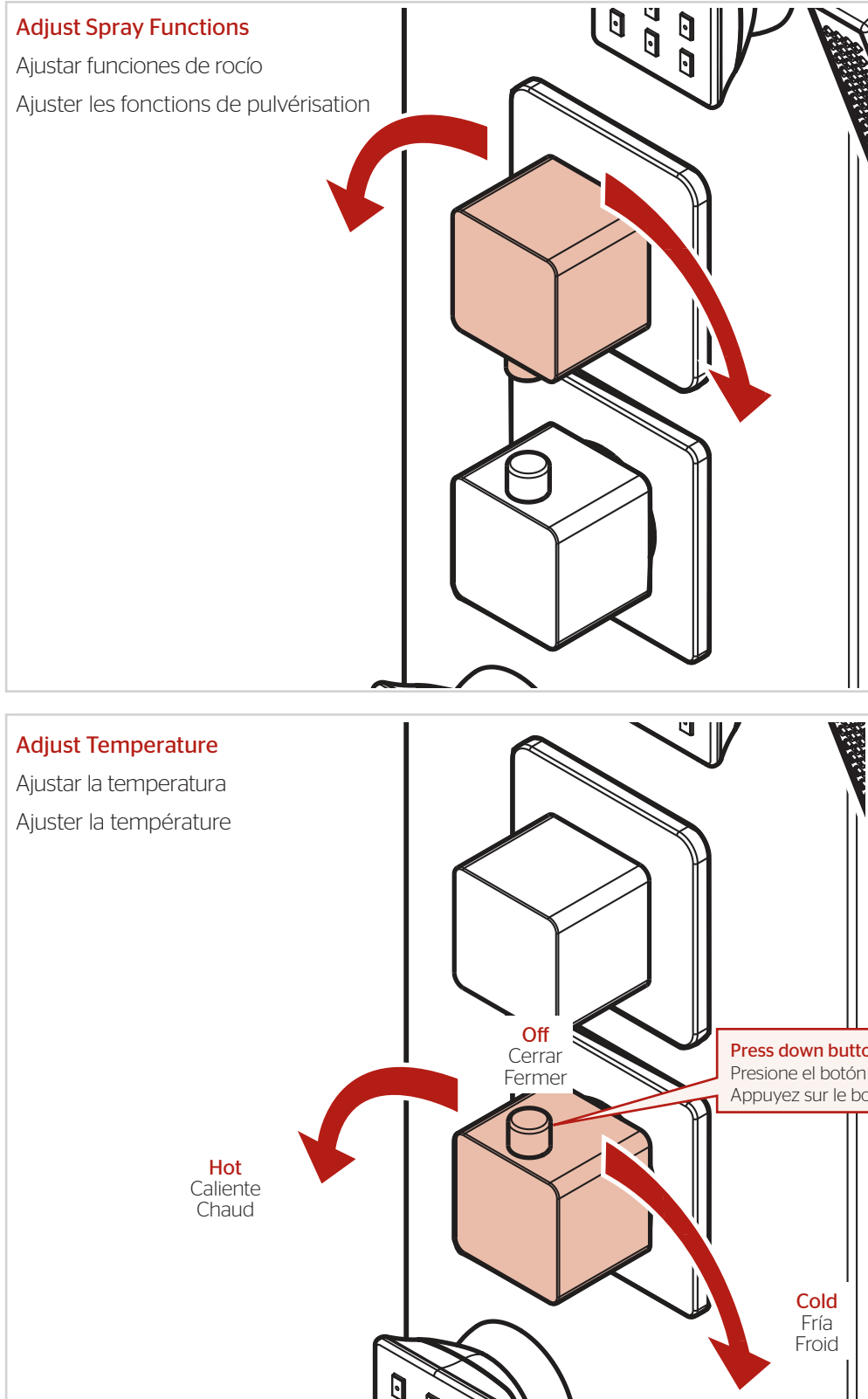

Showerhead

Cabeza de Ducha
 Pomme de Douche

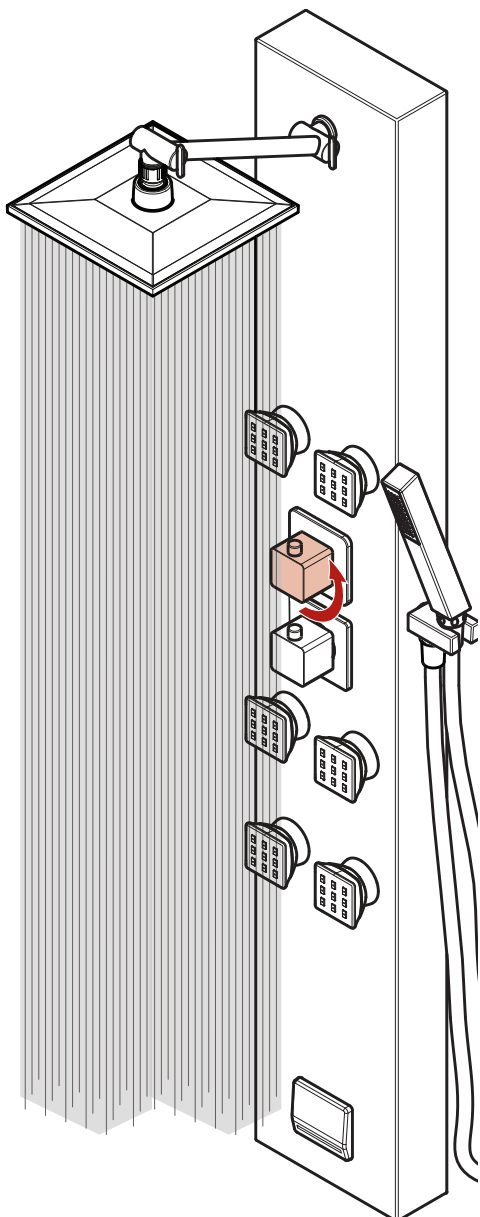
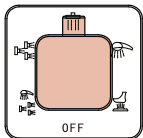

Toe Tester

Probador del Dedo del Pie
 Testeur du Doigt de Pied

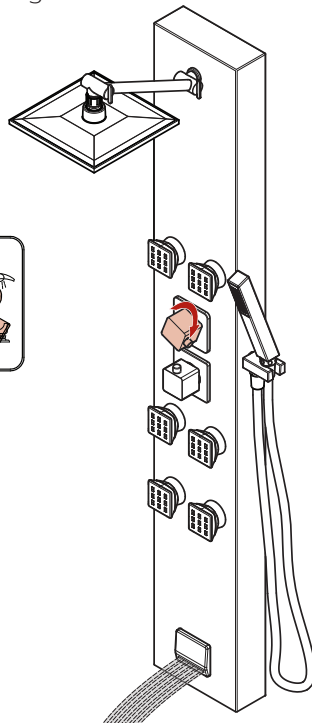
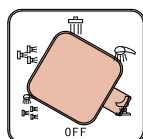

Hand Shower

Ducha de mano
 Douche à main

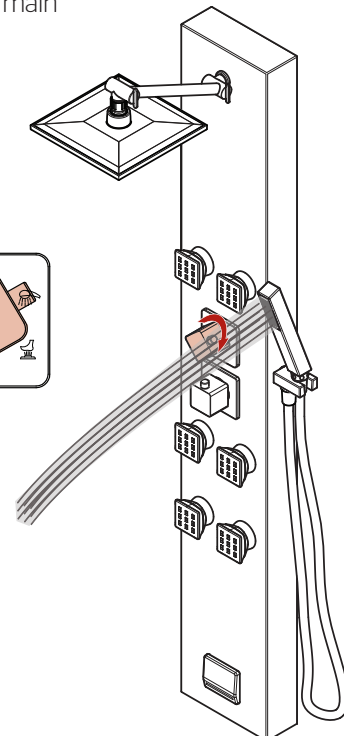
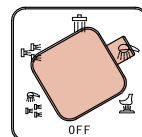

Body Jets

Chorros de Corporal
 Jets du Corps

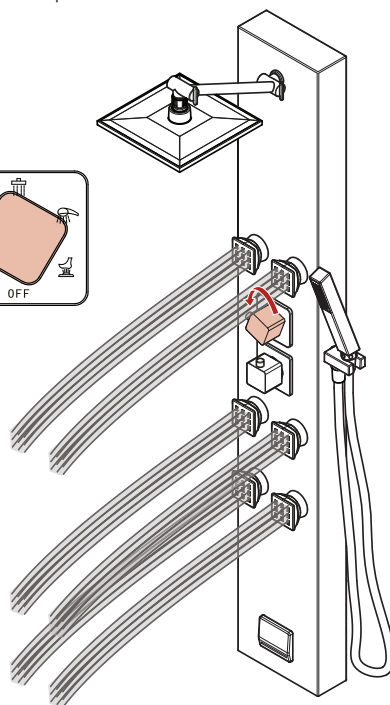
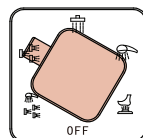

Hand Shower and Body Jets

Ducha de mano y Chorros de Corporal
 Douche à main et Jets du Corps

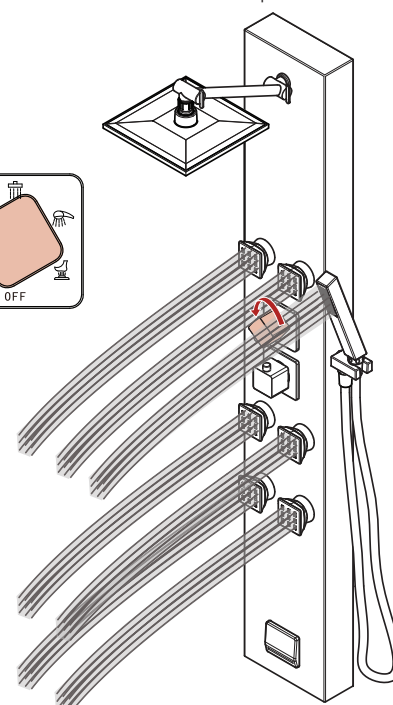
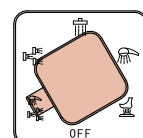

For Additional Installation Help:

Para la instalación adicionales de ayuda:
 Pour les aides supplémentaires à l'installation:

Pfister
 FAUCETS

1-800-PFAUCET (732-8238)
pfisterfaucets.com