

Installation Support • Soporte de instalación • Support d'installation

Personal Assistance, Product Specs, & "How-to" Questions:

Asistencia personal, especificaciones del
producto y preguntas sobre "cómo hacerlo":

Aide personnelle, spécifications du produit
et questions « pratique-pratiques » :

1-800-340-7608
pfisterfaucets.ca



WARNING / ADVERTENCIA / AVERTISSEMENT

To reduce the risk of injury or property damage, read all instructions before installing product. Wear safety goggles. Product must be installed in accordance with all state & local plumbing & building codes. Call a professional if you are uncertain about installing this product. Mounting surface must be clean and level before installing toilet. If not level, use shims according to manufacturer's instructions.

Para disminuir el riesgo de lesiones o daños a la propiedad, lea todas las instrucciones antes de instalar el producto. Utilice gafas de seguridad. El producto deberá instalarse de acuerdo con la normativa de plomería y construcción estatal y local. Llame a un profesional si no está seguro sobre cómo instalar este producto. Ubique las entradas del suministro de agua y cierre la válvula de suministro de agua. Generalmente se encuentran debajo del tanque del inodoro. Si se trata de un reemplazo de inodoro, quite el inodoro viejo y limpie completamente la superficie.

Pour réduire le risque de blessures ou de dommages, lire toutes les instructions avant d'installer le produit. Porter des lunettes de sécurité. Le produit doit être installé en conformité avec tous les codes de construction et de plomberie locaux et de l'état. Appelez un professionnel si vous n'êtes pas certain de la façon d'installer ce produit. Localisez l'entrée de l'approvisionnement en eau et fermer la vanne d'alimentation en eau. On les trouve généralement sous le réservoir de la toilette. Si il ya une toilette de remplacement, retirez la vieille toilette et nettoyer la surface.

Required Tools Herramientas necesarias Outils nécessaires



Phillips Screwdriver
Destornillador de estrella
Tournevis Phillips



Safety Goggles
Anteojos de seguridad
Lunettes de sûreté



Adjustable Wrench
Llave ajustable
Clé à mollette



Caulking or Sealant
Calafateo o sellante
Calfeutrage ou mastic



Cloth
Paño de limpieza
Chiffon

Not Included No Incluido Non Inclus

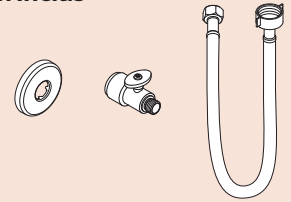

Parts in the Box Piezas en la caja Pièces dans la boîte

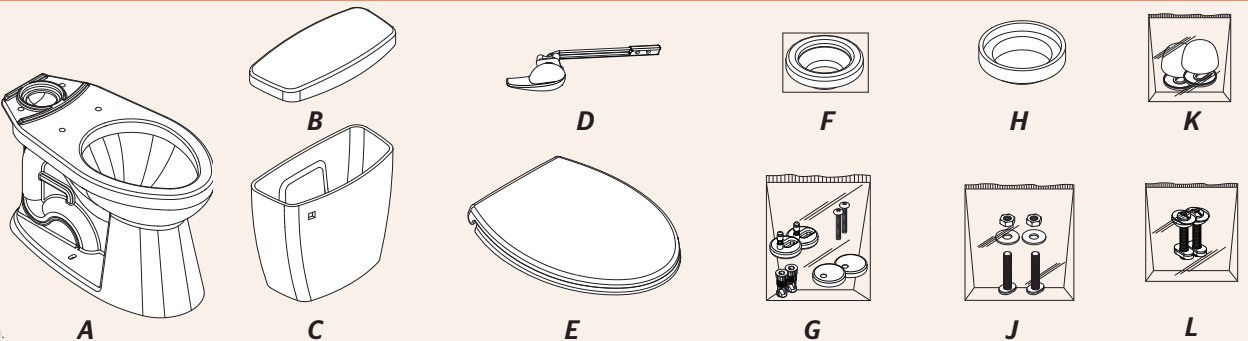

Items shown are not to scale.
De resultados no están a escala.
Produits affichés ne sont pas à l'échelle.

1 Turn Off Water Supply • Cierre el suministro de agua • Couper l'alimentation en eau



Locate water supply inlet and shut off the water supply valve. These are usually found under the toilet tank. If you are replacing an existing toilet, remove the old toilet and clean the surface thoroughly.

Ubique las entradas del suministro de agua y cierre la válvula de suministro de agua. Generalmente se encuentran debajo del tanque del inodoro. Si se trata de un reemplazo de inodoro, quite el inodoro viejo y limpie completamente la superficie.

Localisez l'entrée de l'approvisionnement en eau et fermer la vanne d'alimentation en eau. On les trouve généralement sous le réservoir de la toilette. Si il ya une toilette de remplacement, retirez la vieille toilette et nettoyer la surface.

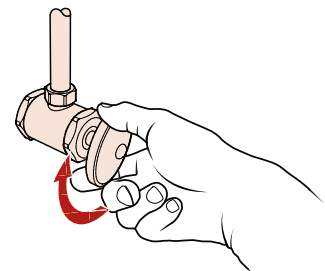

2 Work Area inspection Inspección del Área de Trabajo Inspection de la Zone de Travail

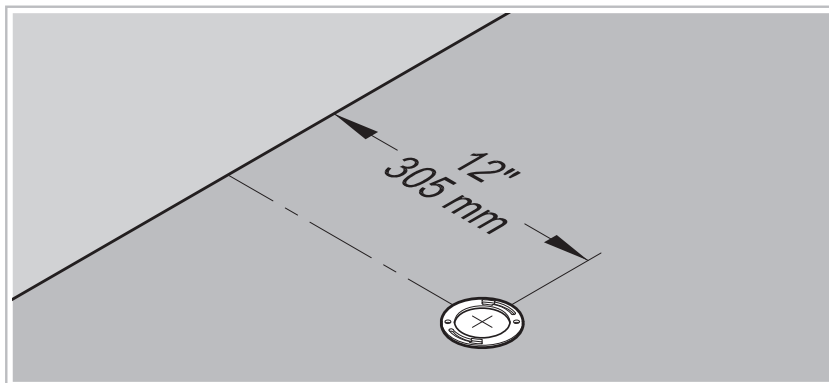

Mounting surface must be clean and level before installing toilet. If surface can't be leveled, use shims according to manufacturer's instructions.

La superficie de montaje debe estar limpia y nivelada antes de instalar el inodoro. Si la superficie no puede ser nivelada, use calzas de acuerdo con las instrucciones del fabricante.

La surface de montage doit être propre et de niveau avant d'installer les toilettes. Si la surface ne peut pas être mise à niveau, en utilisant des cales selon les instructions du fabricant.

3 Install New Wax Seal Instalar Nuevo Sello de la Cera Installer un Nouveau Joint de Cire

*No Tools Required for This Step
No se necesitan herramientas para este paso
Pas d'outil nécessaire pour cette étape*

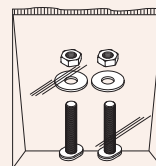

J

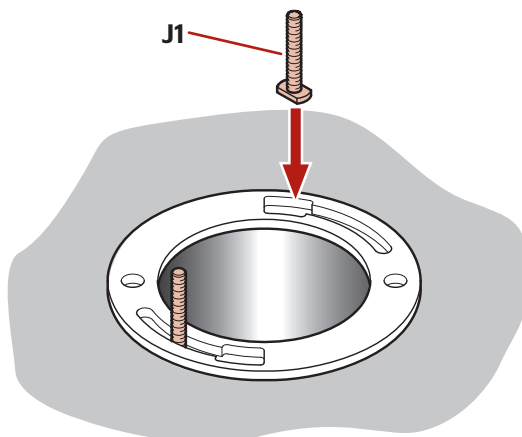

4 Bowl Installation

Instalación de la Taza del Inodoro

Installation de la Cuvette des Toilettes

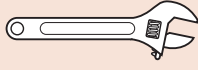

Adjustable Wrench
Llave ajustable
Clé à mollette

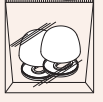
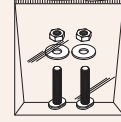
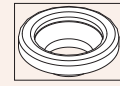

A

F

J

K

4A

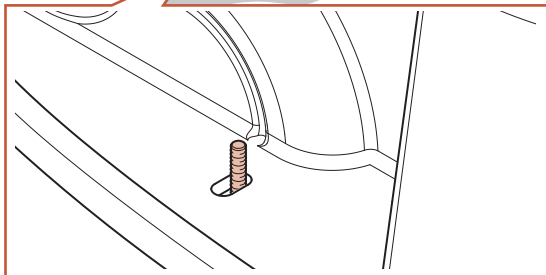
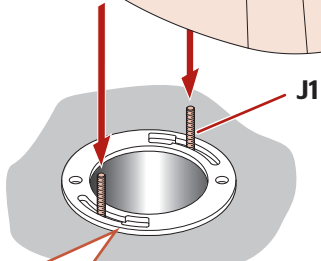
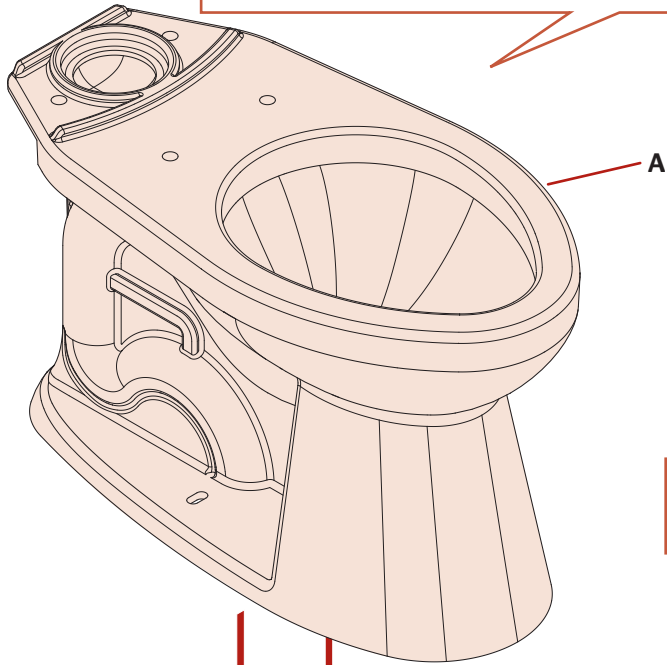
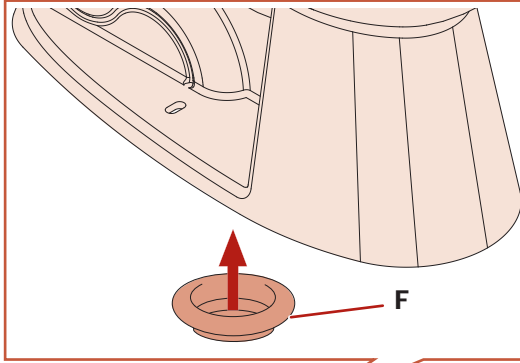

4B

x2

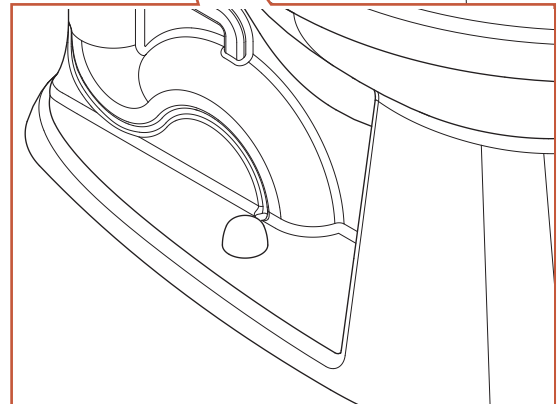
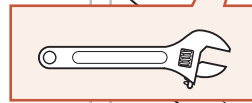
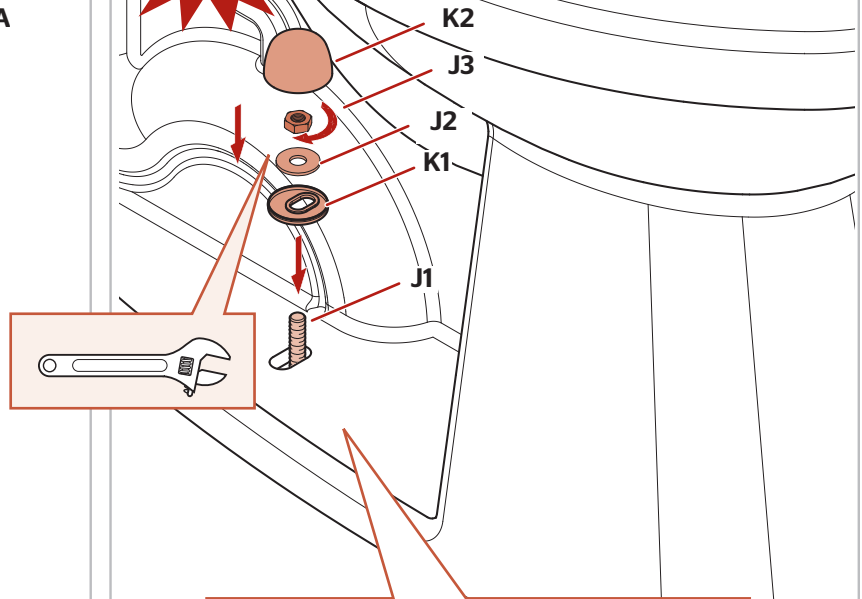

5

Install Tank Instale el Tanque Installez le Réservoir

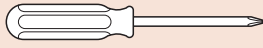

Phillips Screwdriver
Destornillador de estrella
Tournevis Phillips

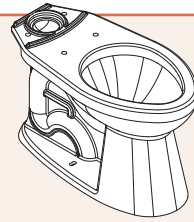

A

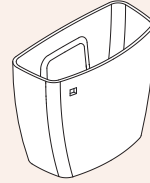

C



H

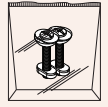

L

5A

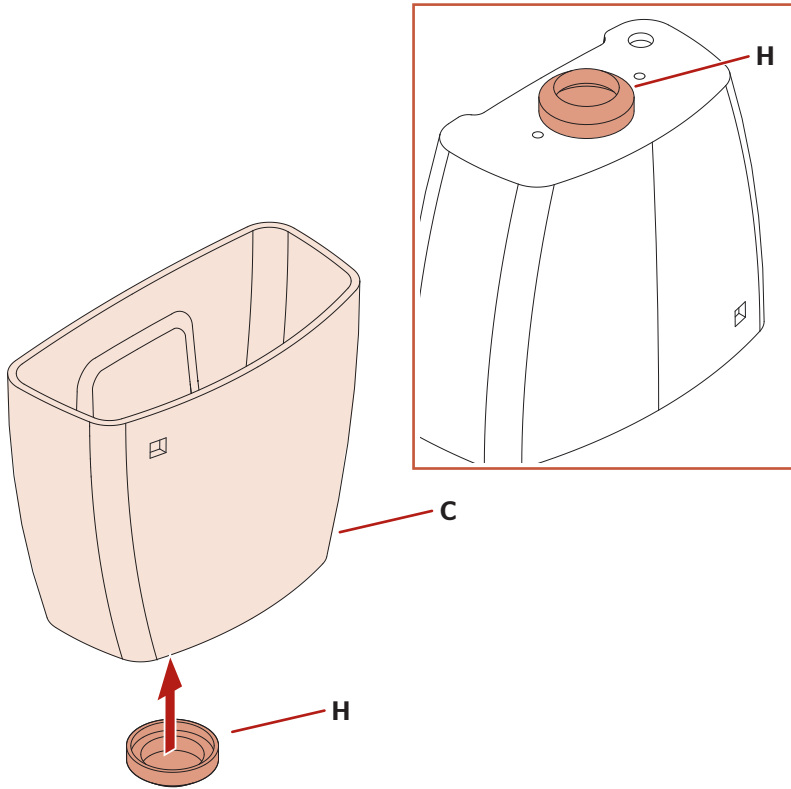

5B

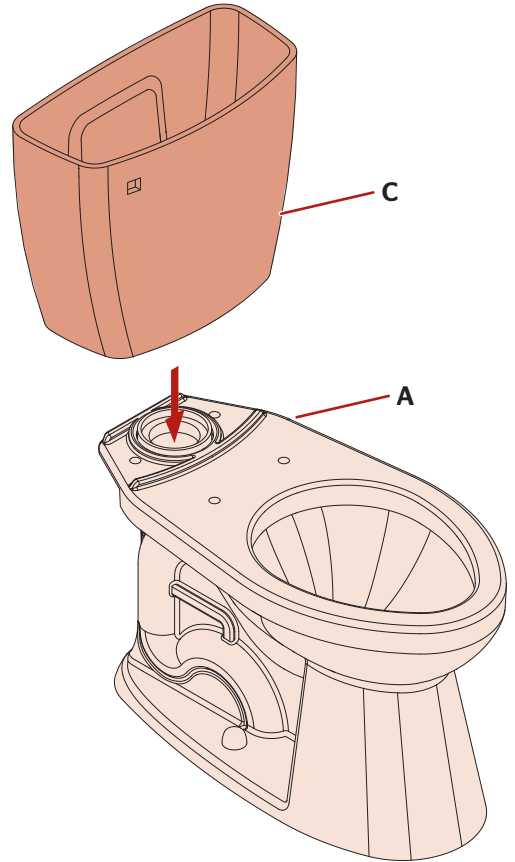

5C

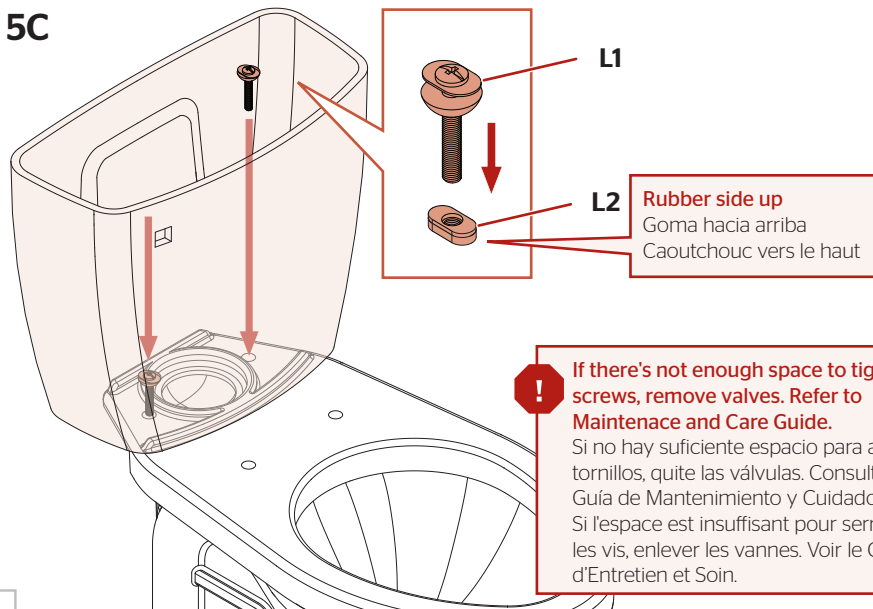

5D

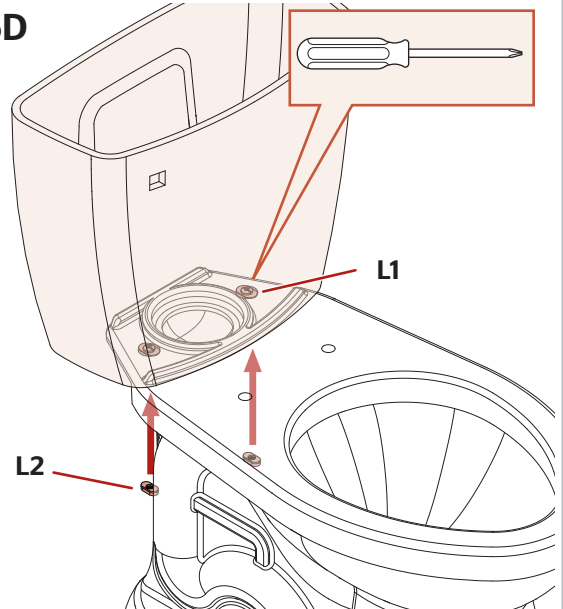

6

Toilet Seat Installation Instalación del Asiento del Inodoro Installation du Siège de Toilette

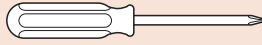

Phillips Screwdriver
 Destornillador de estrella
 Tournevis Phillips

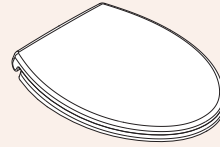

E

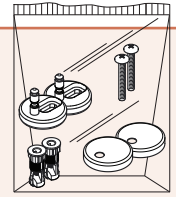

G

6A



Ensure seat is aligned with hinges before final tightening
 Asegúrese que la silla esté alineada con bisagras antes de apretar
 Assurer siège est aligné avec charnières avant le serrage final

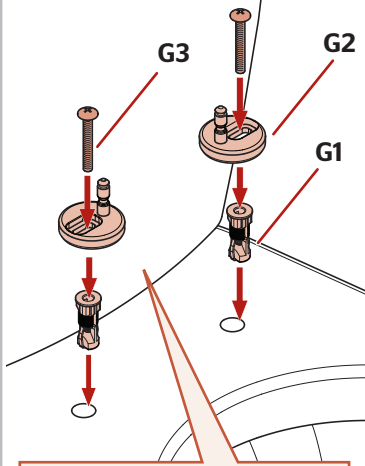

Remove blue wrap
 Quite la envoltura azul
 Retirer le film bleu

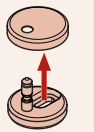

6B

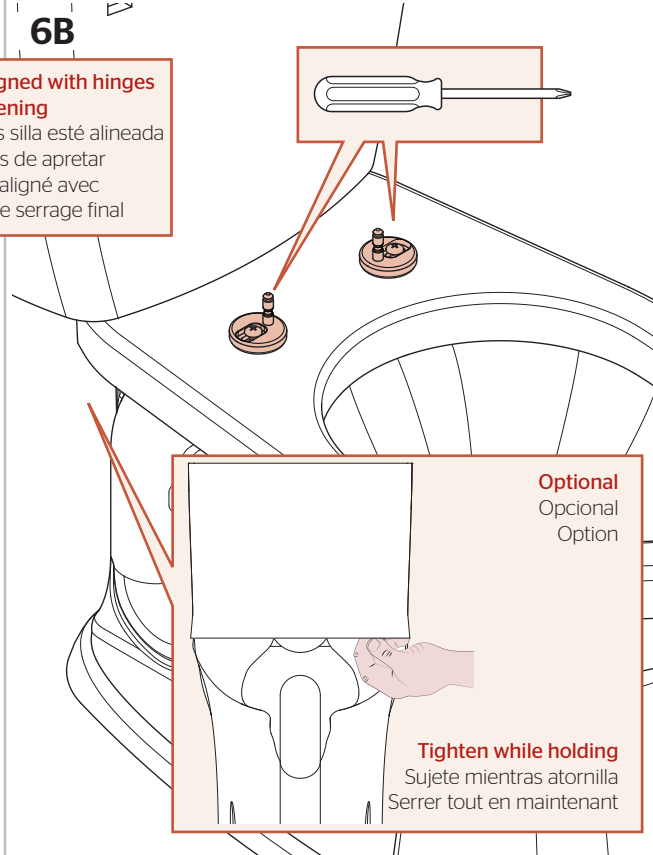
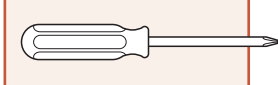

Optional
 Opcional
 Option

Tighten while holding
 Sujete mientras atornilla
 Serrer tout en maintenant

6C

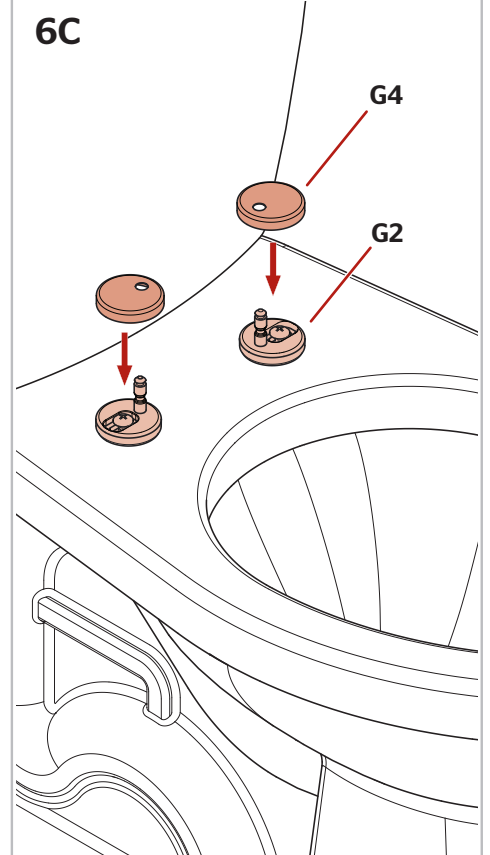

6D

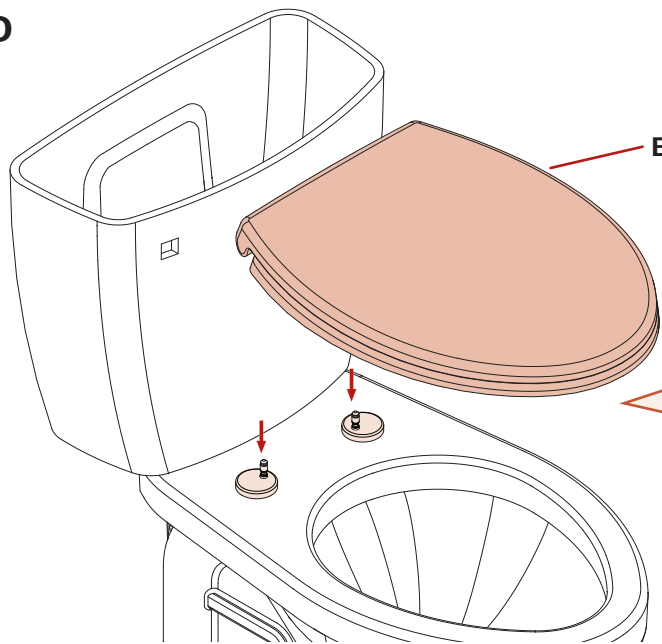

E

Ensure holes on lid are centered, if not they can be adjusted with a screwdriver

Asegúrese de que los orificios en la tapa están centrados, si no se puede ajustar con un destornillador
 Assurez-vous que les trous sur le couvercle sont centrés, sinon ils peuvent être réglés avec un tournevis

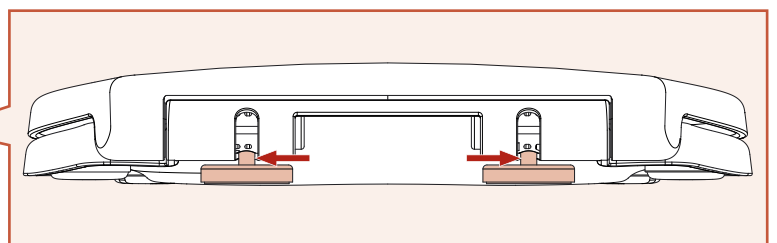

7

Install Lid and Button

Instale la Tapa y el Botón

Installez le Couvercle et Bouton



Caulking or Sealant
Calafateo o sellante
Calfeutrage ou mastic

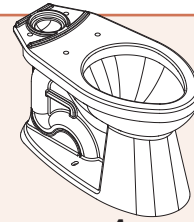

A

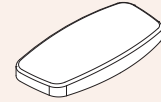

B



D

7A

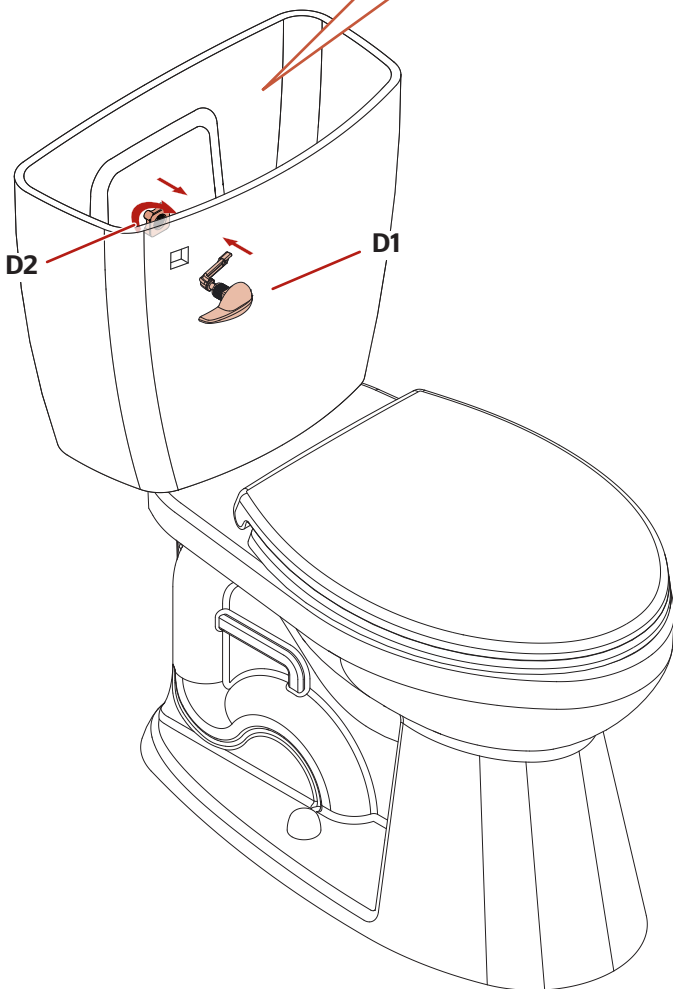
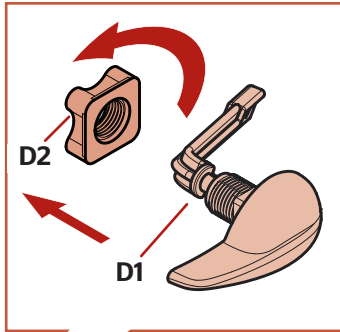

7B

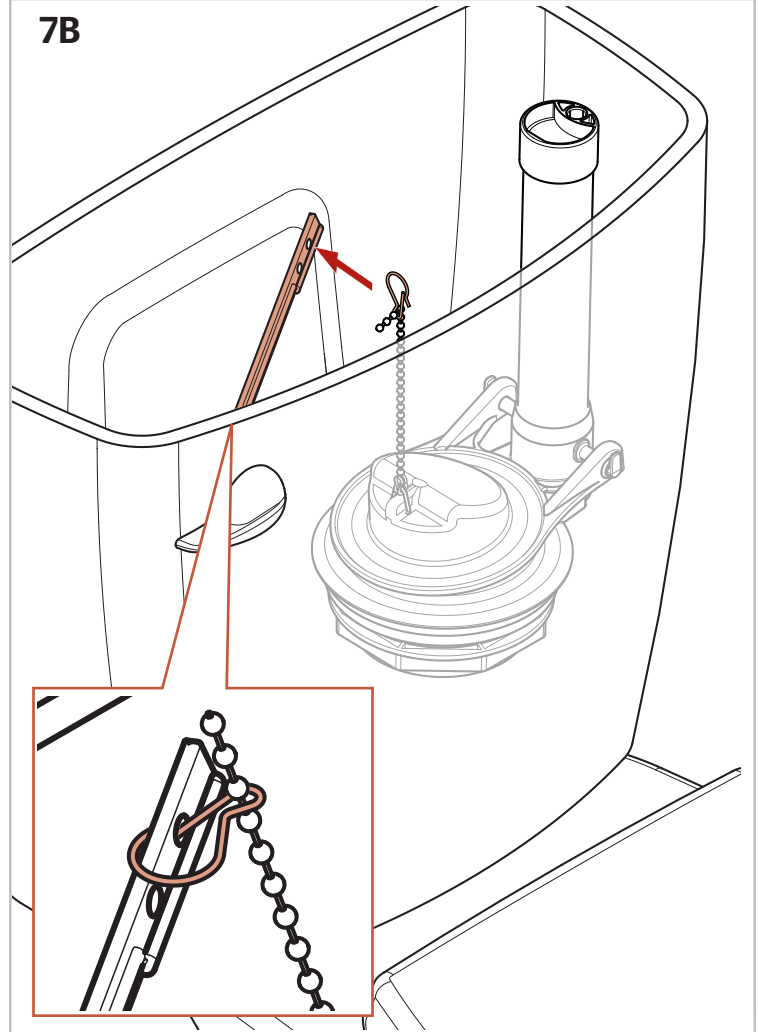

7C

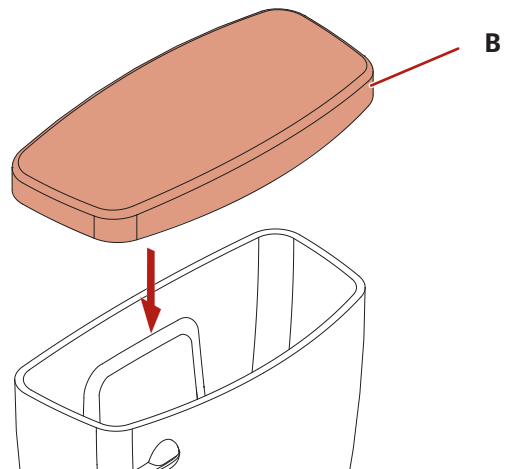

8

Supply Line Installation and Application of Sealant

Instalación y Aplicación de la Tubería de Suministro y Sellante

l'installation de la Conduite d'alimentation et l'application du Matériau d'étanchéité



Caulking or Sealant
Calafateo o sellante
Calfeutrage ou mastic

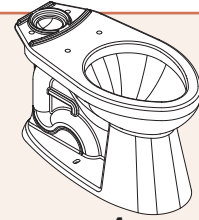

A

8A

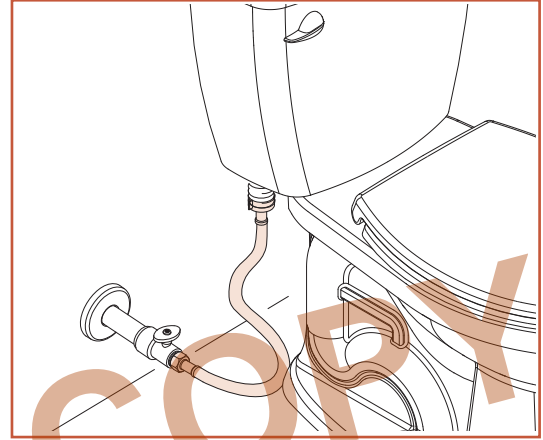
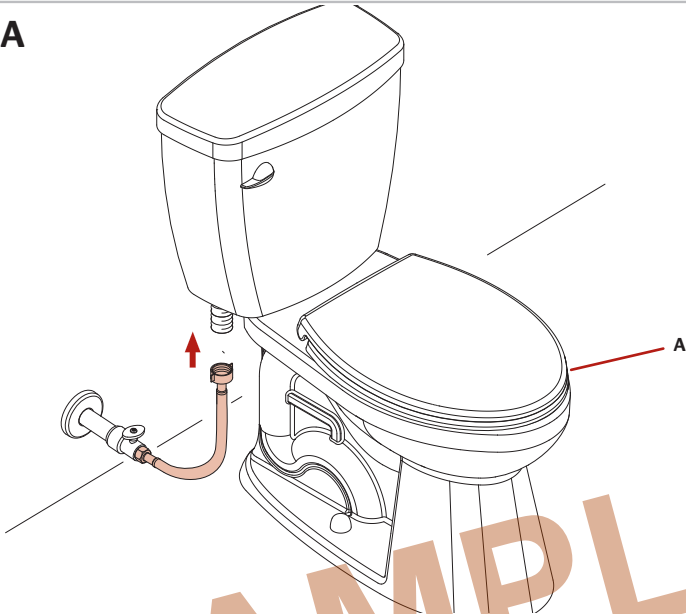

Supply line is not included

La línea de suministro no está incluida
La ligne d'alimentation ne sont pas inclus

8B

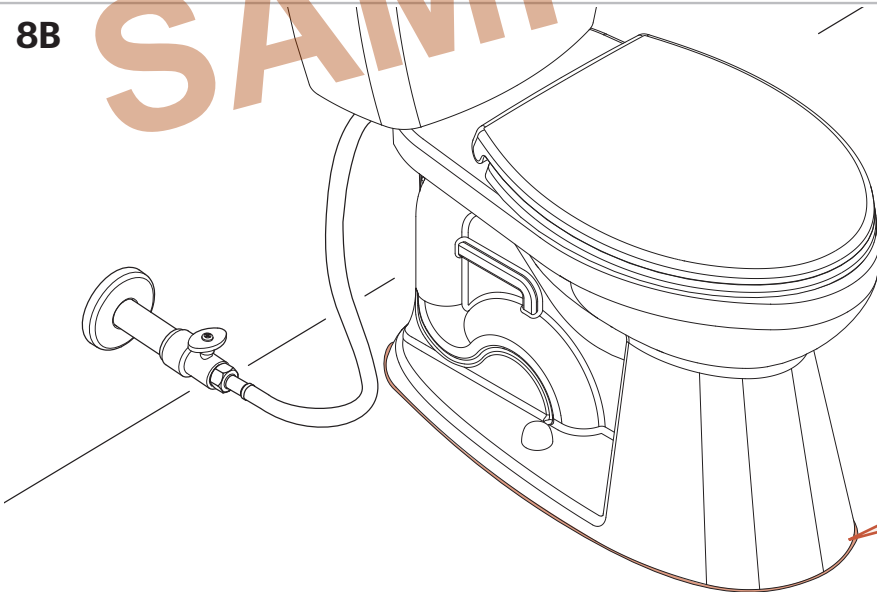

Check for leaks BEFORE using sealant

Compruebe si hay fugas ANTES de usar sellador
Vérifier les fuites AVANT d'utiliser étanchéité

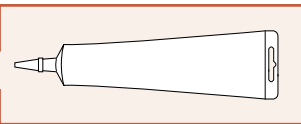

For Additional Installation Help:
Para la instalación adicionales de ayuda:
Pour aider à l'installation supplémentaires:

Pfister®

1-800-340-7608
pfisterfaucets.ca